

ROHS

REV	修正前 BEFORE REVISION	修正后 AFTER REVISION	姓名 SIGN	日期 DATE
V1.0	新规格		June	20200221

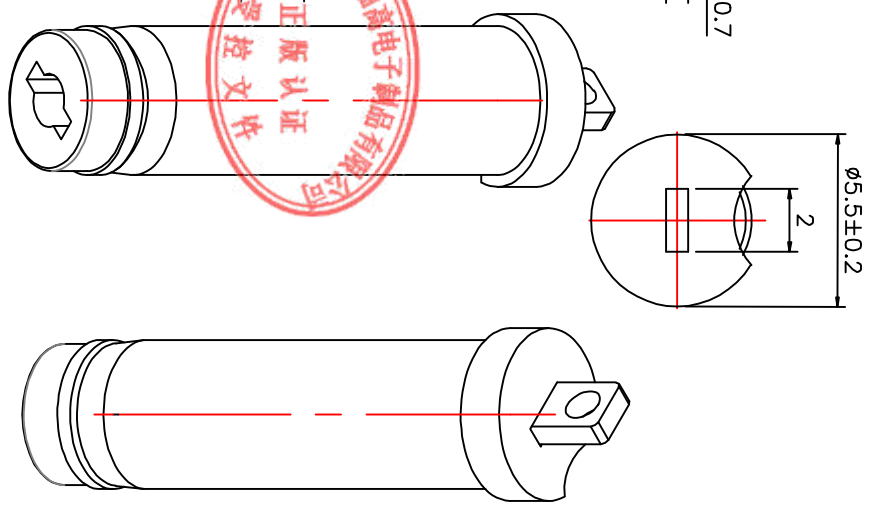
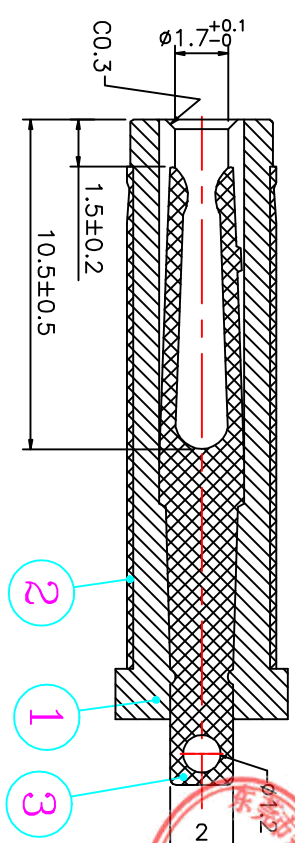
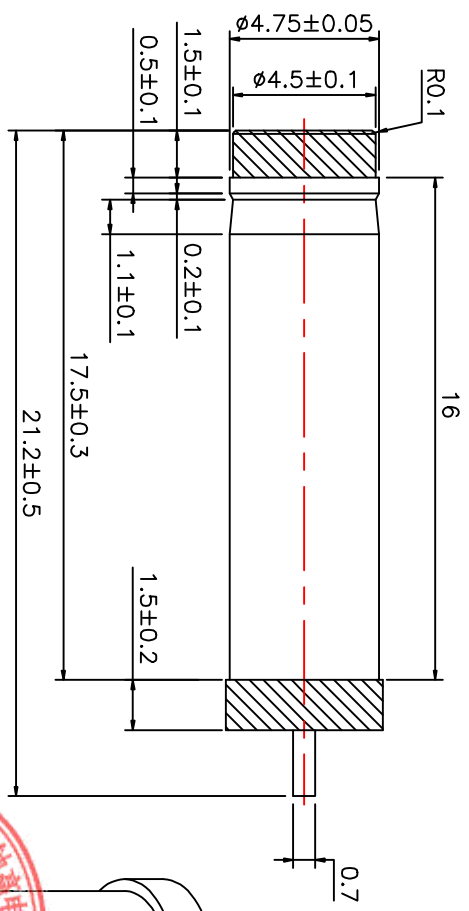
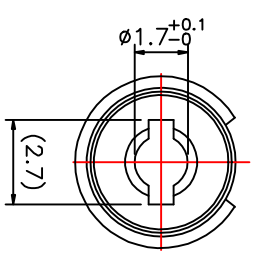

**Technology Request:**  
 1. Outlock: No hurt, no hurt.  
 2. Electronic performance:  
 a: Insulation resistance: Above DC500V/100M Ω;  
 b: Reduce voltage: AC500V at 1 minute;  
 c: Contact resistance: Under 30m Ω;  
 3. Insertion force & withdrawal force: 0.3-3kgf.  
 4. Salt spray test: 48H.  
 5. Meet RoHS.  
 6. Remark \* is important specification.

单位 Unit	一般公差 The General Tolerance	7	8	9	10	11	12	13	14
比例 Scale	XX:±0.3	5							
视图 Third angle projection	X:X:±0.1	3	4017*19.7毫米片	CS191	Ni 2um-5um	June	杨义邦	苏伟伦	规格 DESCRIPTION: DC PLUG 4.75*4.1.7*21.2
	.XX:±0.05	2	4.75*16毫米管	H65	Ni 2um-5um				品名 P/N: 47517TV212M15
		1	PLASTIC	PA66	BLACK				图号 DRAWN NO: CP-01-0191
		NO.	PART	MATERIAL	PLATING				

